

QBD series Pockels cell driver

User Manual

Overview

QBD series Pockels cell drivers produce high voltage pulses with high repetition rates, fast risetimes (falltimes) and adjustable voltage amplitude. Drivers are available in two modifications: QBD-DN for pull-down scheme and QBD-UP for push-up scheme.

Pulse parameters

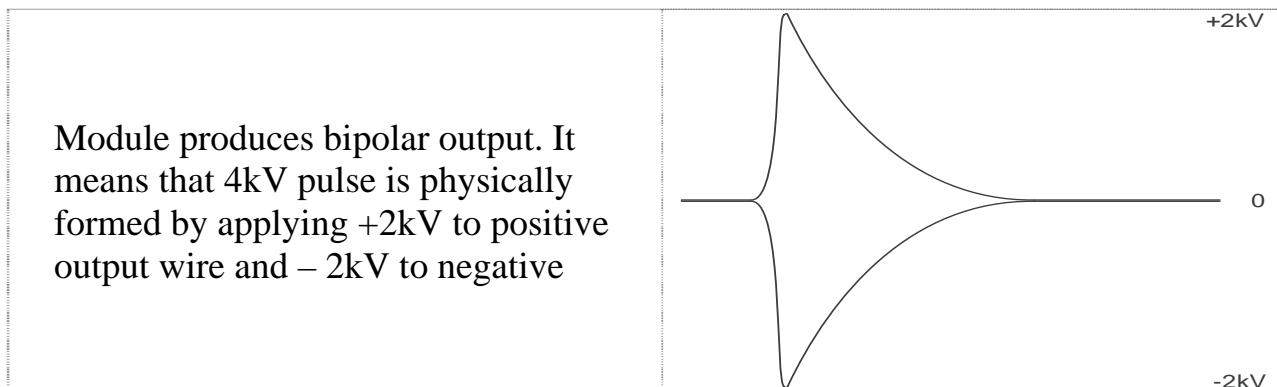

Attention! Further description of HV output will be given in terms of voltage differences. Please keep it in mind!

Typical pulse shape (QBD-DN modification)	
Typical pulse shape (QBD-UP modification)	
Risetime/Falltime	~20 ns ^{1, 2}
Recovery time ²	~10 us @ 100 pF load
HV pulse amplitude	from HVmin to HVmax ³
Repetition rates	from single shot to ~100 kHz ²

¹ at 10-90% level

² depends on HV pulse amplitude and capacity load

³ HVmin and HVmax values see in part number table

Connections, signals, signal descriptions

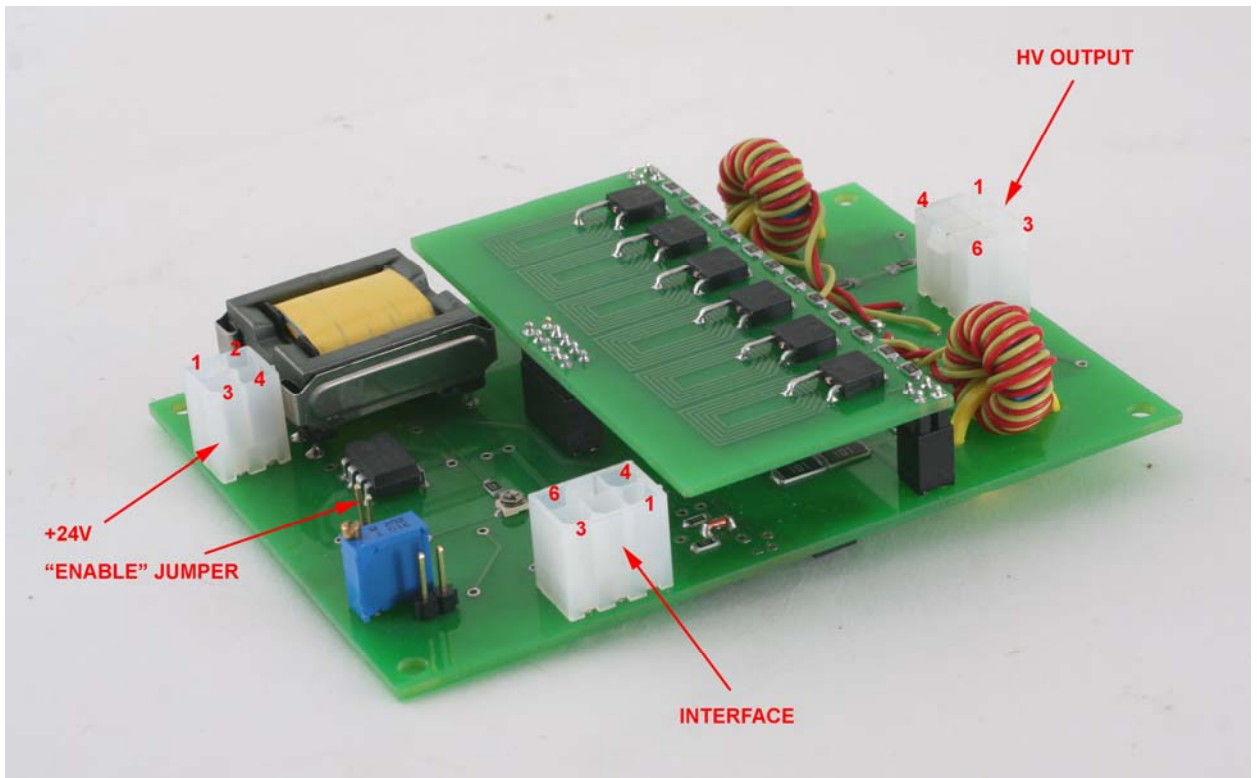

There are three connectors at Pockels cell driver board. Hereafter is description of corresponded female connectors (supplied with the board)

+24V (Molex 39-30-1040):



PIN (color)	DESIGNATION	DESCRIPTION
1, 2 (red)	+24V	INPUT positive 24VDC for turn on the Pockels cell driver Regulation: 22-28V, typical
3, 4 (black)	RETURN	Return from power supply producing +24VDC

INTERFACE (Molex 39-30-1060):

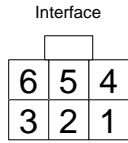

PIN (color)	DESIGNATION	DESCRIPTION
1 (orange)	Q-switch	Step from “0” or ”1” on PIN1 forms Q-Switched pulse on Pockels Cell
2, 4 (black)	Interface Return	PIN2 and PIN4 are connected to the circuit ground of all internal circuits
3 (blue)	Enable	The high voltage output is enabled by PIN3 (“1” – enable, “0” – disable)
5 (purple)	HV Monitor	The voltage at PIN5 is a monitor signal proportional to the measured value of high voltage output HVmax corresponds to 10V at PIN5, HVmin corresponds to approx. 4V at PIN5
6 (yellow)	HV Program	Positive DC voltage applied to PIN6 sets up high voltage value HV HVmax corresponds to 10V at PIN6, HVmin corresponds to approx. 4V at PIN6

“0” means logical 0 low level (0V), “1” means logical 1 high level (5V)

INTERFACE CIRCUITS

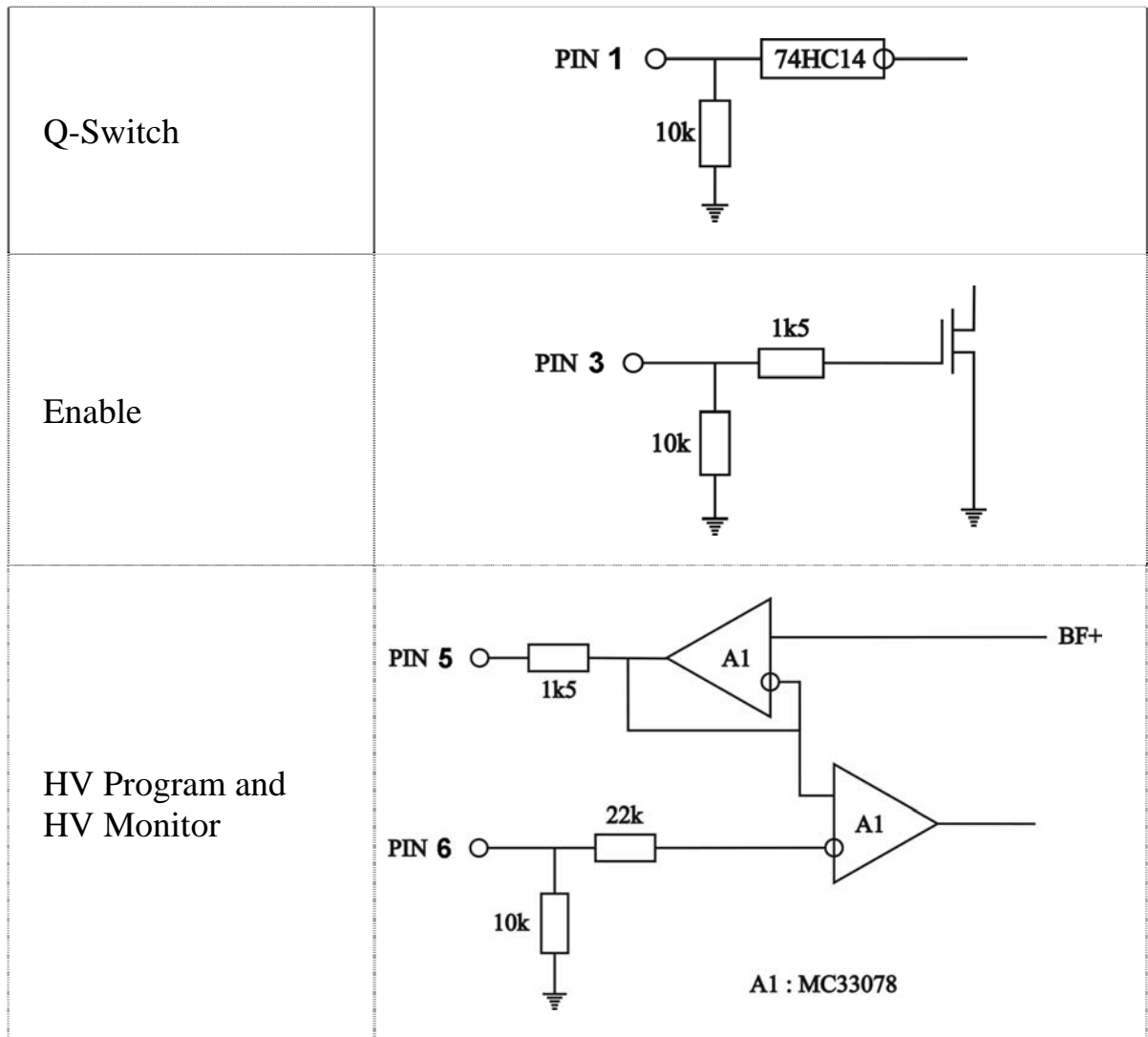

HV OUTPUT (Molex 39-30-1060):

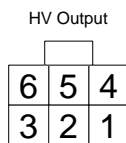

QBD-series, UP-modification			QBD-series, DN-modification		
PIN (color)	DESIGNATION	DESCRIPTION	PIN (color)	DESIGNATION	DESCRIPTION
1, 4 (blue)	Negative	HV Negative	1, 4 (red)	Positive	HV Positive
2, 5	N/C		2, 5	N/C	
3, 6 (red)	Positive	HV Positive	3, 6 (blue)	Negative	HV Negative

Safety

Warning! This equipment produces high voltages that can be very dangerous. Don't be careless around this equipment.

- To provide safety the QBD-series Pockels cell driver module is designed to be powered with supply voltage +24VDC, which must be galvanically separated from mains.
- It is the user's responsibility to ensure that personnel are prevented from accidentally contacting the QBD-series Pockels cell driver module, especially the high voltage connector and cable. **Casual contact could be fatal.** Output cables must have good isolation for output voltage and low capacitance.
- After shut down, do not touch the load until it has been discharged. Use an appropriate measurement device to check for complete discharge.
- Disconnect the QBD-series Pockels cell driver module from DC power supply before changing electrical or mechanical connections.

Operations

1. Connect all wires
2. **Disable** the high voltage output
3. Apply the correct nominal **DC Input** power to the module
4. Set up the required output voltage by applying a DC voltage to the **HV Program PIN6** of **INTERFACE**
5. **Enable** the high voltage output
6. To start Pockels cell driver set driving pulses from "0" to "1" of necessary repetition rate to PIN1 of **INTERFACE**. Set pulse length not less than 5us
7. To power down the QBD-series, remove **DC Input** power or **Disable** high voltage output

Specification

ELECTRICAL SPECIFICATION

Input	+24V DC; 0,8A max
Output	
Risetime/Falltime	~20ns(depends on load)
Recovery time	depends on load (~10us@100pF)
HV pulse amplitude	see Part number table
Repetition rate	up to 100kHz
Capacity load	up to 500pF
Safety	
Leakage current	not more then 150μA
Environment	
Operation Temperature	-20...+45C
Storage Temperature	-40...+85C
Humidity	90%, non-condensing

MECHANICAL SPECIFICATION

Size (LxWxH)	110x80x25 mm
Weight	0,1 kg

DRAWINGS

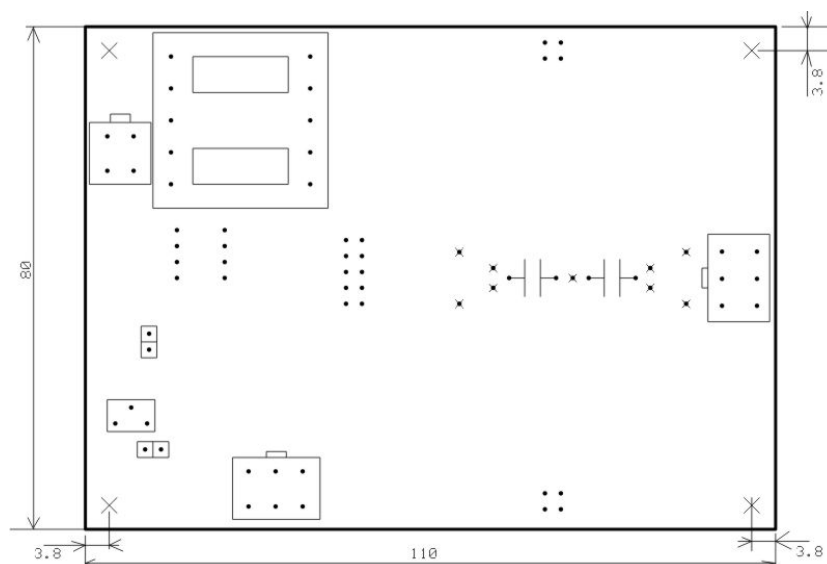

Part number table

Part Number	HVmax	HVmin
QBD-5020-DN QBD-5020-UP	5000	2000
QBD-4016-DN QBD-4016-UP	4000	1600
QBD-3012-DN QBD-3012-UP	3000	1200
QBD-2008-DN QBD-2008-UP	2000	800

Suffics “DN” means pull-down scheme, “UP” – push-up scheme (see also *Pulse parameters* section)

Typical output

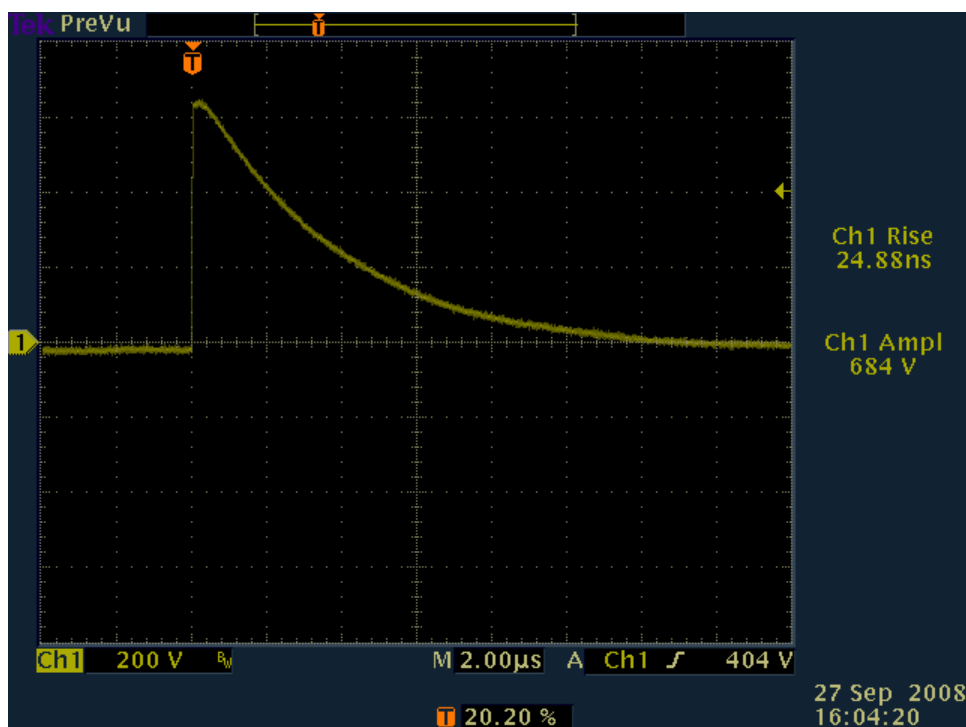

time scale: 2us / div

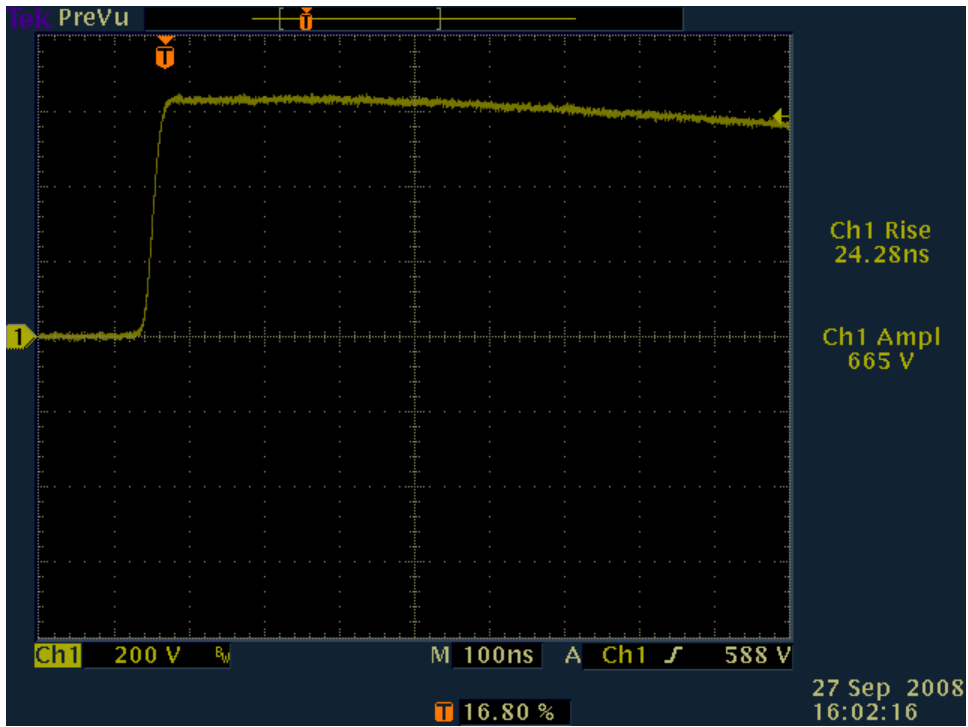

time scale: 100ns / div

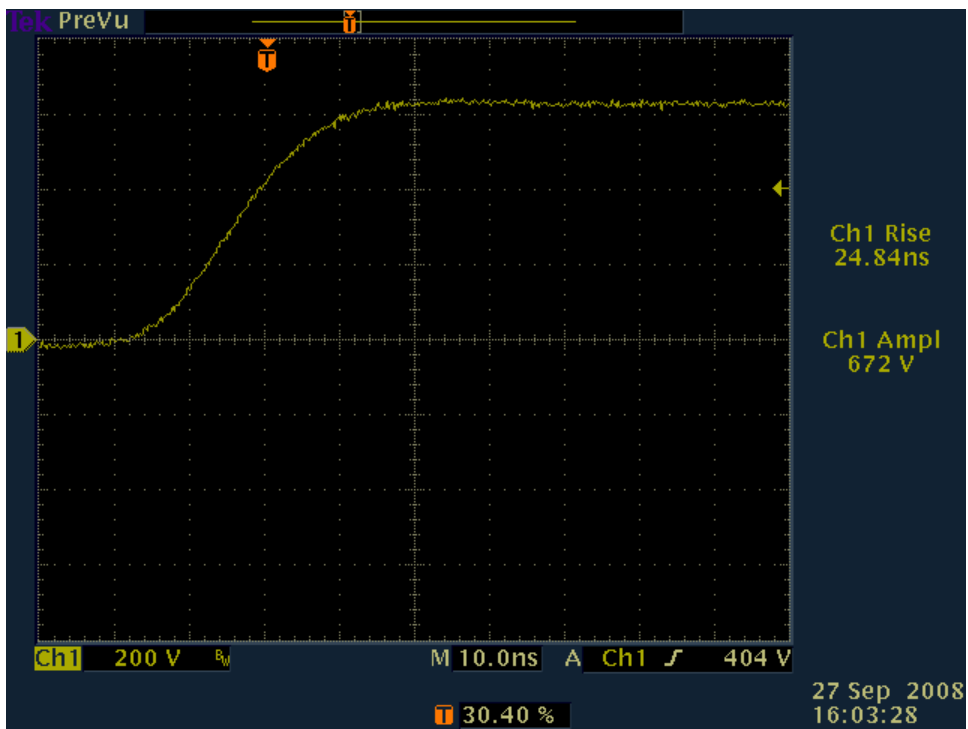

time scale: 10ns / div