

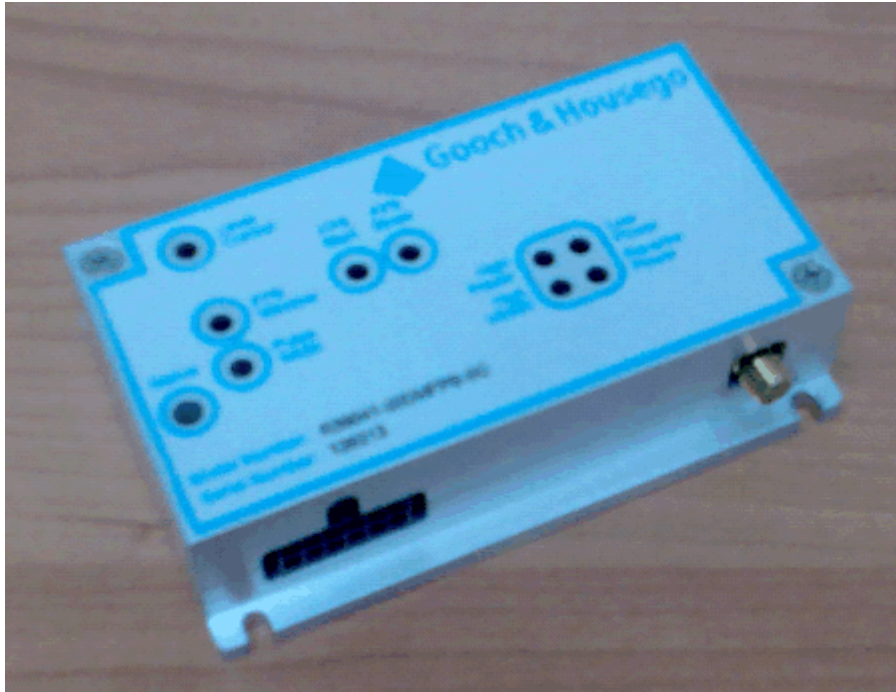

风冷 Q 开关电源 R39041-20DMFPS-SC

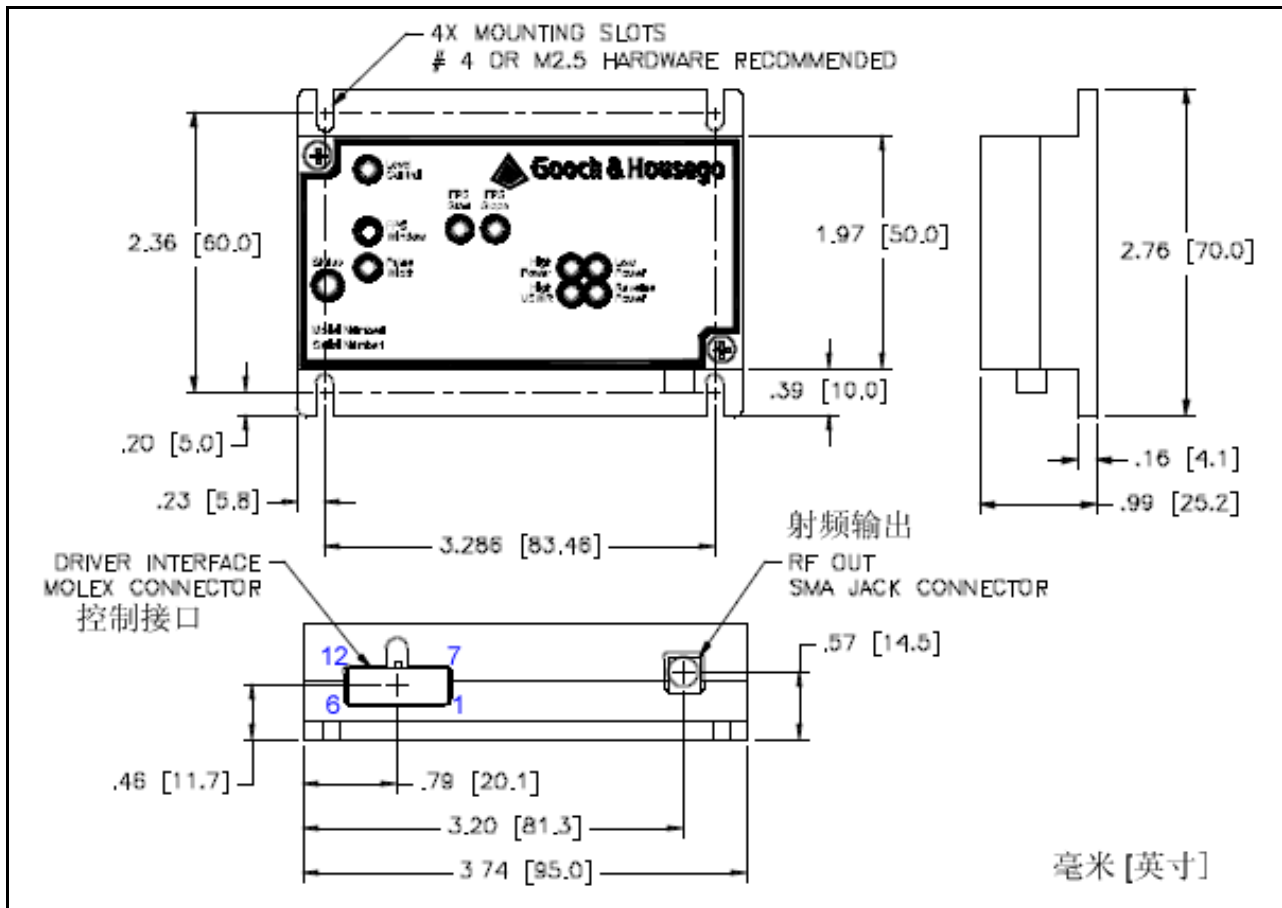

外形尺寸:



12 针控制接口接头说明

脚号	说明
1	Sync Out 同步信号输出
2	FPS Trigger 首脉冲抑止输入（一般用打标的GATE信号）
3	Mod In Fixed 固定脉宽调制输入（一般用打标的频率信号）
4	Ground 地线
5	Mod In Variable 可变脉宽调制输入（一般用打标的频率信号）
6	Mod In Analog 模拟调制输入（用于控制射频输出功率大小）
7	Zero Cross 过零控制（一般不用）
8	LP - Low Power Fault Output 低功率故障指示输出
9	HP - High Power Fault Output 高功率故障指示输出
10	High VSWR Fault Output VSWR故障指示输出
11	Enable (Stand By) 使能控制（一般不接）
12	+15VDC 直流电源输入

注：1、要么选用固定脉宽调制输入，要么选用可变脉宽调制输入，不能同时使用。

2、对FPS和PPK型电源，PIN6是空脚，不需要输入信号。

3、对A05和R05型电源，PIN2是空脚，不需要输入信号。

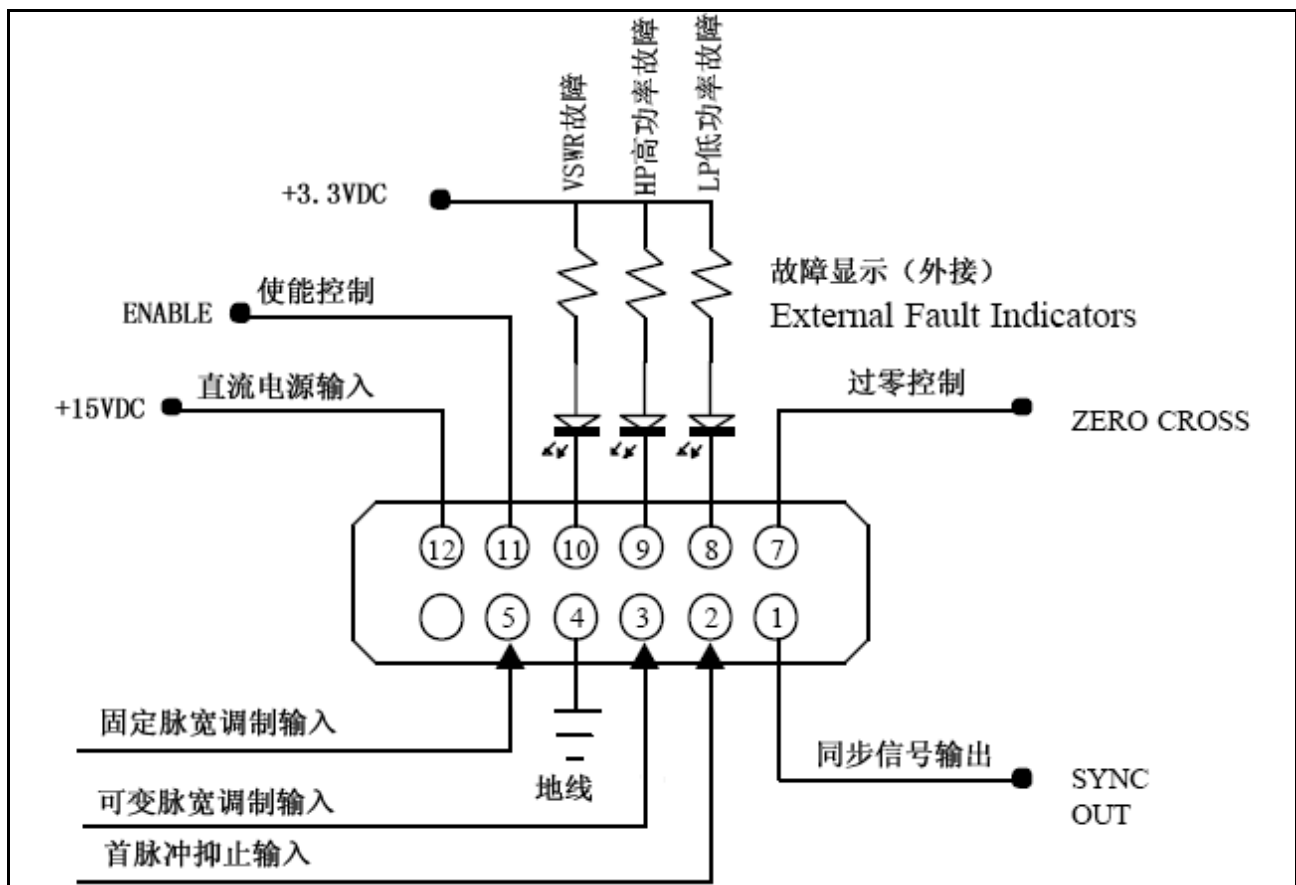

波形图

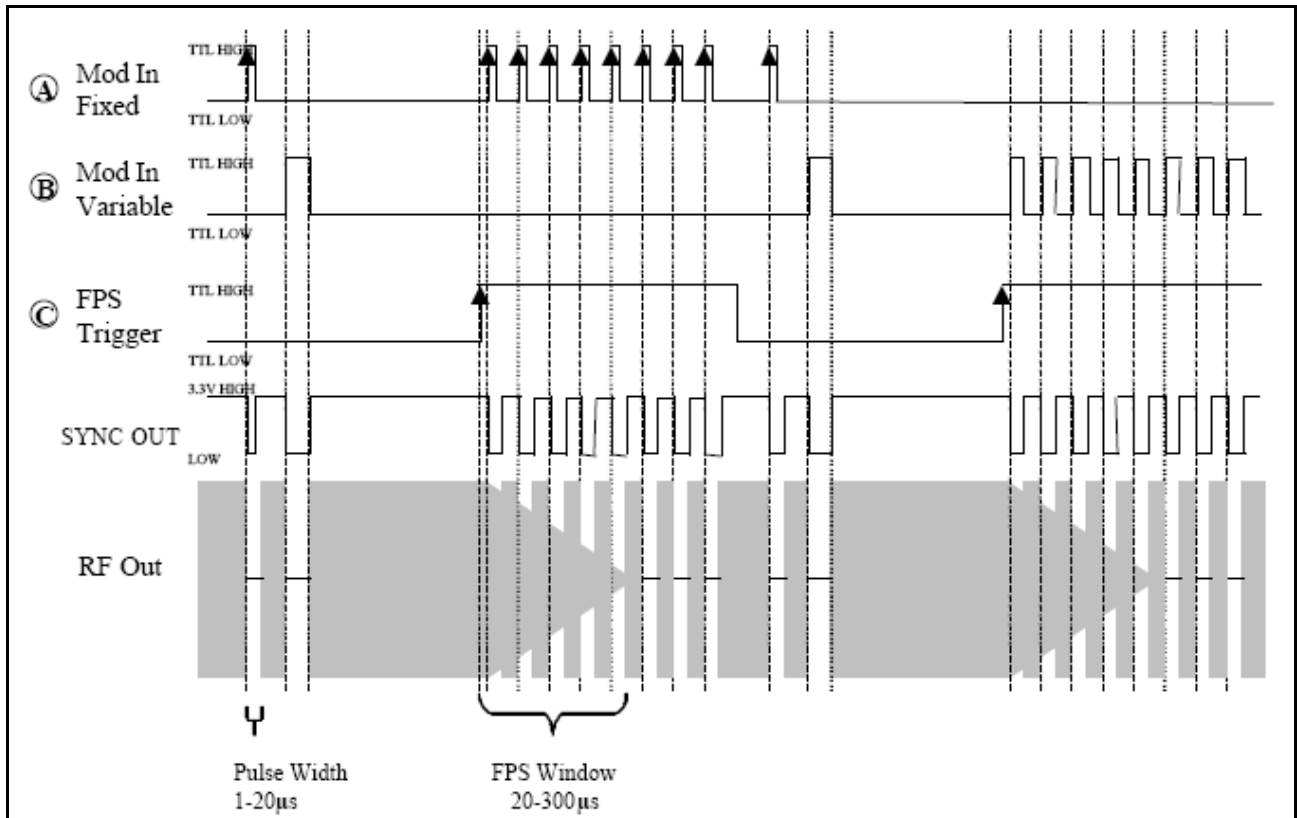

控制方式设置-下图中SW1中的开关3和4

控制方式 (ZZZ)	开关3状态	开关4状态
FPS	On 开	Off 关
PPK	On 开	On 开
R05	Off 关	Off 关
A05	Off 关	On 开

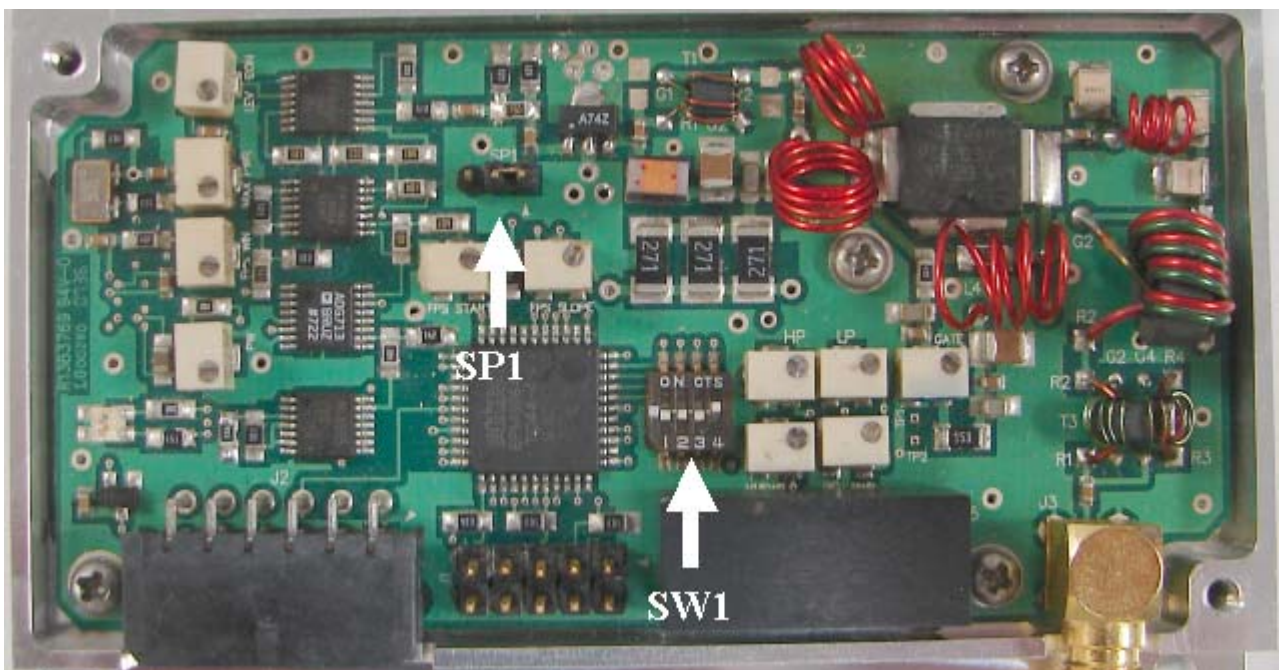

上图显示的是 A05 控制方式（开关 3 和 4 分别设置成关和开状态），如需要改变控制方式，改变开关 3 和 4 的状态就行了。

Operation Manual

LOW POWER, COMPACT Q-SWITCH DRIVER (2-24 WATT)

R390XX-YYDMZZZ-SC

XX = 24, 27, 41 YY = 2 to 24 D = Digital Modulation M = Compact OEM Module

ZZZ = Control Options: FPS, PPK, A05, R05



Sintec Optronics Pte Ltd

Sintec Optronics Pte Ltd

We, Sintec Optronics Pte Ltd, are a Singapore-based supplier of a wide range of photonics products (lasers & parts, optical components, and relevant accessories). We provide various high-quality low-price lasers, parts & optics for OEM and end users. The company is managed by experienced professionals with engineering & servicing backgrounds. Our customers range over 32 countries around the world.

1. Lasers

- 1.1 Sealed CW CO2 lasers
- 1.2 CW Nd:YAG laser systems
- 1.3 Diode-pumped YAG lasers
- 1.4 Diode pumped green lasers
- 1.5 Pulse Nd:YAG lasers
- 1.6 High-power diode lasers
- 1.7 Red diode lasers
- 1.8 Diode-pumped green lasers
- 1.9 Fiber Lasers

2. Optical Components

- 2.1 Focusing lenses
- 2.2 Mirrors & output couplers
- 2.4 Beam expanders
- 2.5 Zoom beam expanders
- 2.6 Beam splitters
- 2.7 Scan mirrors
- 2.8 Scan lenses (f-theta lenses)

3. Accessories

- 3.1 Laser lamps (Kr and Xe lamps)
- 3.2 CW and pulse Nd:YAG laser power supply
- 3.3 Diode laser drivers
- 3.4 Laser chillers/heat exchangers
- 3.5 Laser crystals & optical crystals (YAG rods, KTP, BBO, ZnSe etc)
- 3.3 AO & EO Q-switches & drivers
- 3.4 AOMs
- 3.5 Laser power/energy meters
- 3.6 Laser safety goggles
- 3.7 Optical scanners/galvanometers
- 3.8 Motorized or manual adjustable XYZ stages & rotary stages
- 3.9 Vertical translation stages
- 3.10 Mirror mounts, holders, posts & holders
- 3.11 Optical tables
- 3.12 CNC control software
- 3.13 Laser marking heads and marking software
- 3.14 Laser pump chambers

We are a leading company in Singapore to provide quality laser systems & optical components and excellent services at attractive prices. We always try our best to make our products reliable, safe, easy to use, flexible and economical. We believe our continuing advances in technologies will make us the best choice to provide the solutions to make you remain competitive and be a leader in your own field.

Sintec Optronics Pte Ltd

Tel: +65 63167112 Fax: +65 63167113

E-mail: sales@sintecoptronics.com OR sales@SintecOptronics.com.sg

URL: <http://www.SintecOptronics.com> AND <http://www.SintecOptronics.com.sg>

TABLE OF CONTENTS

SECTION	TITLE	PAGE
1.	INSPECTION	2
2.	DESCRIPTION	3
3.	SPECIFICATIONS	4
4.	OUTLINE DRAWINGS	5
5.	CONNECTIONS	7
6.	STATUS INDICATOR	7
7	DIP SWITCH AND JUMPER SETTINGS	7
8.	CONTROLS	8
9.	FPS / PPK ADJUSTMENT	9
10.	FAULTS	10
11.	ZERO CROSS, SYNC OUTPUT, AND ENABLE	10
12.	TURN ON AND OPERATING PROCEDURE	11 -12
13.	CONTROL DIAGRAMS	13- 16

INSPECTION

Examine the shipping carton for damage. If the shipping carton or packing material is damaged it should be kept for the carrier's inspection. Notify the carrier and Gooch & Housego of any damage. Check the contents of the shipment for completeness, mechanical damage, and then test the equipment electronically as described in the operating procedures. If the contents of the shipping container are incomplete, or the equipment does not pass the electrical testing please notify Gooch & Housego.

If there is any problem with the use of this equipment, or if the equipment fails to function as expected contact Gooch & Housego, do not try to trouble shoot or repair this equipment. Consult with a Gooch & Housego service engineer. If the equipment needs repair or replacement, contact Gooch & Housego for a Return Authorization Number.

DESCRIPTION

The **R390XX-YYDMZZZ-SC** is a low to medium power radio frequency generator in a compact, OEM package. The driver supplies an RF signal to an acousto-optic Q-Switch, typically in an Nd:YAG laser. The Q-Switch, when excited, deflects a large portion of the laser light off the optical axis of the laser cavity spoiling the gain in the cavity and allowing the energy to be stored in the upper state of the gain media. When the RF is turned off, typically in 50ns, the Q-Switch becomes transparent and a light pulse is output from the laser.

The RF driver has two digital modulation inputs: Fixed and Variable. These controls allow the customer to issue a pulse command of a "Fixed" pulse width, the duration determined by the driver pulse width control, settable by the customer, or issue a "Variable" pulse command, the duration determined by the input signal pulse width. The RF driver may be modulated in "Fixed" duration mode at any frequency from 1 Hz to 500 kHz by an external frequency source. In "Variable" duration mode, the RF driver can be modulated from DC to 500 kHz. The RF energy can be modulated off in a short period of time (50 ns typical). The RF Driver can produce up to 24 watts output into a 50 ohm load.

The R390XX-YYDSZZZ-SC driver is factory configured for RF Frequency, Power, and Control Options when ordered. The **R** in the model number indicates that this product is compliant with the EU Directive 2002/95/EC for **R**eduction of **H**azardous **S**ubstance.

Output RF frequency options: XX = 24, 27, 41, 80

RF frequency = 24.00 MHz, 27.12 MHz, 40.68, or 80.00 MHz

RF power: YY = 2 - - - 24

2 to 24 watts

Factory set to match the matching Q-Switch

Adjustable but limited to no more than 10 % above rating.

The 390XX-YYDMZZZ-SC driver is factory set when ordered with a control option, which determine the type of control of the output power. The options available that control the RF output level for the 39000 drivers include:

Control Option: ZZZ

FPS = First Pulse Suppression See Figure 2

PPK = Pre Pulse Kill See Figure 3

R05 = RF off Analog Control See Figure 4

A05 = Analog Control See Figure 5

View the control diagrams for each type to review the specific differences in options. The option available for the driver is factory set, and is specified by the last three letters of the model number. When the FPS or PPK control option is selected, the circuit is designed to eliminate the large light pulse that is output from the laser after a long period of inactivity. Normally, the first pulse from a Q-Switched laser that has been held off for over 100 ms will be much larger than the subsequent pulse. This excess energy can cause unwanted damage to the target of the laser. The circuit does this by scaling the energy sent to the Q-Switch. The result is that this first pulse has the lower energy compared to the subsequent pulses. When the A05 or R05 control option is selected, the circuit is designed to control the output with an analog input signal allowing intensity control of any pulse. This control is used to vary the output energy of the laser pulse. See the Acceptance Test Report for the specified options for your driver.

SPECIFICATIONS

R390XX-YYDMZZZ-SC COMPACT LOW POWER Q-SWITCH DRIVER

<u>PARAMETER:</u>	<u>SPECIFICATION:</u>
Output Frequency:	<u>XX</u> = 24, 27, 41, or 80 Where RF Frequency = 24.00, 27.12, 40.68, 80.00 MHz \pm 0.01%
Spurious Levels:	-50 dBc Maximum
Harmonic Distortion	-20 dB Maximum
Modulation Input Mod In Fixed (pin 3) Mod In Variable (pin 5)	TTL Levels Triggered on TTL Rising Edge. Pulse Width Applied >50 ns. TTL Levels TTL HIGH = RF Off
Extinction Ratio:	40 dB Minimum
RF Rise Time 10% to 90%	100 ns Maximum
RF Fall Time: 90% to 10%	50 ns Maximum
Modulation Repetition Rates:	1 Hz to 500 kHz for Fixed Modulation DC to 500 kHz for Variable Modulation
Fixed Modulation Output Pulse Width Adjustment Range:	1 to 20 ms, Customer Adjustable
Available Pulse Suppression Modes:	<u>ZZZ</u> = Mode
Modulation Operating Mode is "Factory Set" Internally.	FPS = First Pulse Suppression PPK = Pre Pulse Kill R05 = RF Switched to Analog Control A05 = Analog Control
FPS Trigger (pin 2) for Pulse Suppression for Units Configured with FPS, PPK:	TTL Levels, Triggered on TTL Rising Edge.
Analog in (pin 6) for Power Control for Units Configured with A05, R05:	0 to 5 volts Analog.
Enable - Stand by Mode (pin 11)	< 3 watt dissipation in stand by mode. TTL High or no connection = Normal operation TTL Low = Stand by Mode Momentary TTL Low = Driver Reset - after fault is removed.
Zero Crossing Enable (pin 7) normally: If model # is (-ZC):	TTL high or no connection- disabled, TTL low- enabled TTL high or no connection- enabled, TTL low- disabled
Sync out (pin 1)	Outputs 3.3 volt signal
RF Power Output:	<u>YY</u> watts where YY = 2 to 24 watts
Output Impedance:	50 W
Supply Voltage:	+15 VDC
Supply Current:	< 3 amps.
<u>OPERATING TEMPERATURE:</u>	+10 to +55 ⁰ C Case Temperature
Contact Cooled	The Driver must be attached to a heatsink capable of dissipating 25 watts
<u>MAXIMUM RATINGS:</u>	
Supply Voltage:	+18 volts
Power Output:	No DC Feedback Allowed
Storage Temperature:	-20 to + 85 ⁰ C

OUTLINE DRAWING

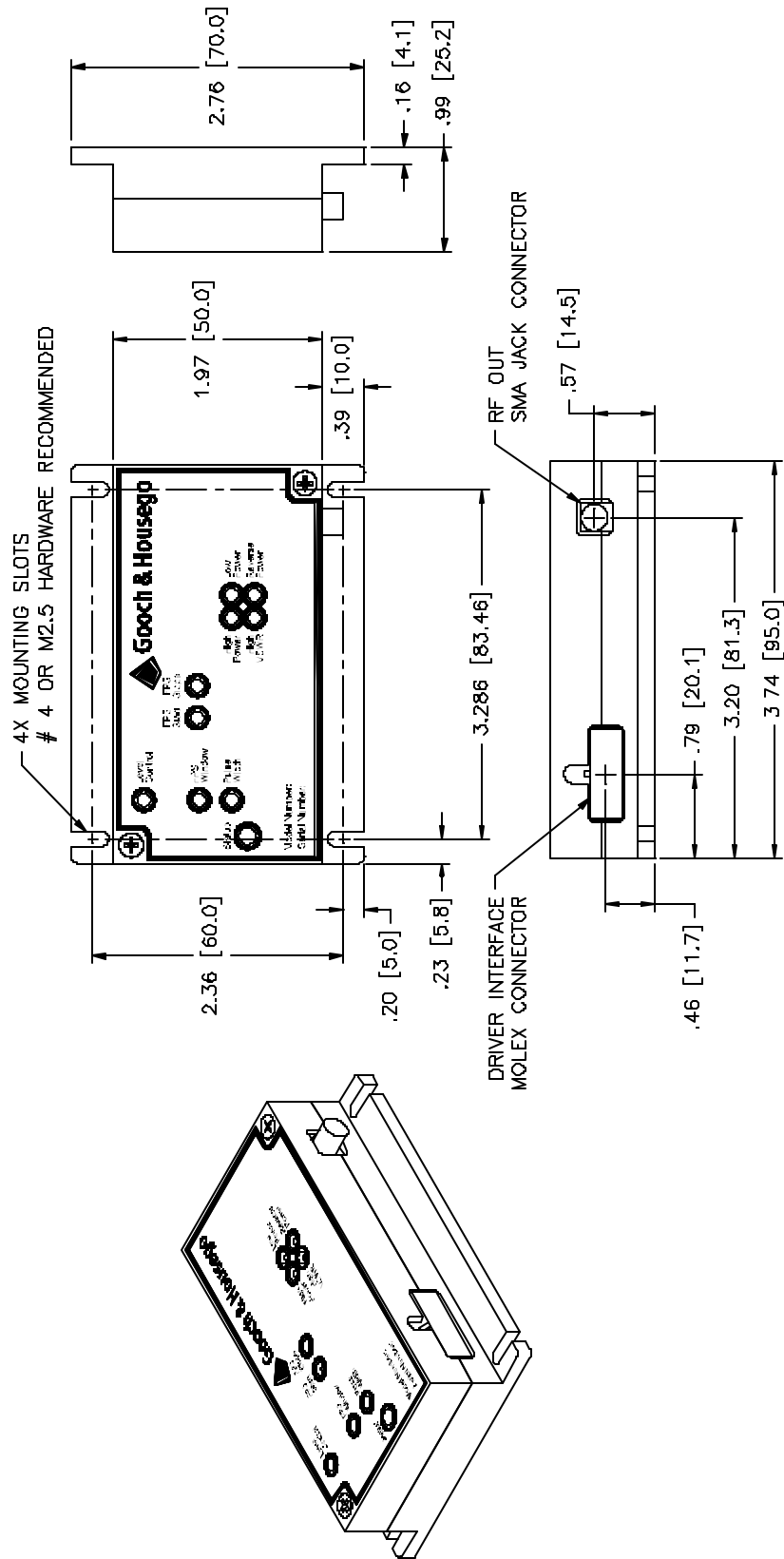

CONNECTIONS

RF Output Connector: SMA Female
 Connector: 12Pin Connector – Molex p/n 43045-1221
 Pinout:

1	Sync Out	7	Zero Cross
2	FPS Trigger	8	LP - Low Power Fault Output
3	Mod In Fixed	9	HP – High Power Fault Output
4	Ground	10	High VSWR Fault Output
5	Mod In Variable	11	Enable (Stand By)
6	Mod In Analog	12	+ 15 VDC

STATUS INDICATOR

Red	Normal Operation	= TTL High or no connection on pin 11
Green	Stand By Mode	= TTL Low on pin 11
Yellow	Fault Condition	
	Momentary TTL Low on pin 11 = Driver Reset - after fault is removed	

DIP SWITCH SETTINGS*

Digital Modulation Polarity – Switch 1

ON (Default)	OFF
Variable Mod – TTL Low = RF On, pin pulled low	Variable Mod – TTL High= RF On, pin pulled high
Fixed Mod and FPS Trigger on Rising Edge	Fixed Mod and FPS Trigger on Falling Edge

Zero Cross – Switch 2

ON	OFF (Default)
Zero Cross - Active on TTL High	Zero Cross - Active on TTL Low

Control Mode (ZZZ) – Switches 3, 4

Control Mode (ZZZ)	Switch 3	Switch 4
FPS	On	Off
PPK	On	On
R05	Off	Off
A05	Off	On

JUMPER SETTINGS*

Analog Input

Pins 1 – 2 Jumpered (Default)	Pins 2 – 3 Jumpered
0 V = Minimum RF, 5 V = Maximum RF	0 V = Maximum RF, 5 V = Minimum RF

* The Unit you receive is factory set to the modulation polarity, zero cross, and the control mode settings as specified when ordered. If you need to reset any of the Factory set control conditions for your driver, then, **any change must be done under direction of a Gooch & Housego Engineer by Email FAX or Phone.**

CONTROLS

Level Control	Adjusts the output RF Power.
Low Power Set Point	Adjusts the minimum power threshold. If the module's output goes below this set value, the LP pin goes low, but the driver will continue to output power. This is not a true fault condition.
High Power Set Point	Adjusts the maximum power threshold. If the output rises above this threshold, the HP pin goes low.
High VSWR Set Point	Adjusts the module's tolerance for a mismatched load connected to RF Out. If a mismatch is detected, the driver will cease outputting power until reset by momentarily entering stand by mode.
Reverse Power Set Point <u>Normally disabled</u>	Adjust the maximum power reflected back from load. (option instead of VSWR)
Pulse Width	Adjusts the length of time the driver outputs no RF energy after receiving a Fixed Input trigger. 1 μ s to 20 μ s.
The following adjustments are used on units configured with FPS or PPK: See Next Page	
FPS Start	Adjusts the initial power level of the first pulse.
FPS Slope	Adjusts how quickly the RF pulses return to their normal level after the FPS has been triggered. 20 μ s to 300 μ s.
FPS Window	Adjusts the duration of the suppression pulse cycle. 20 μ s to 300 μ s

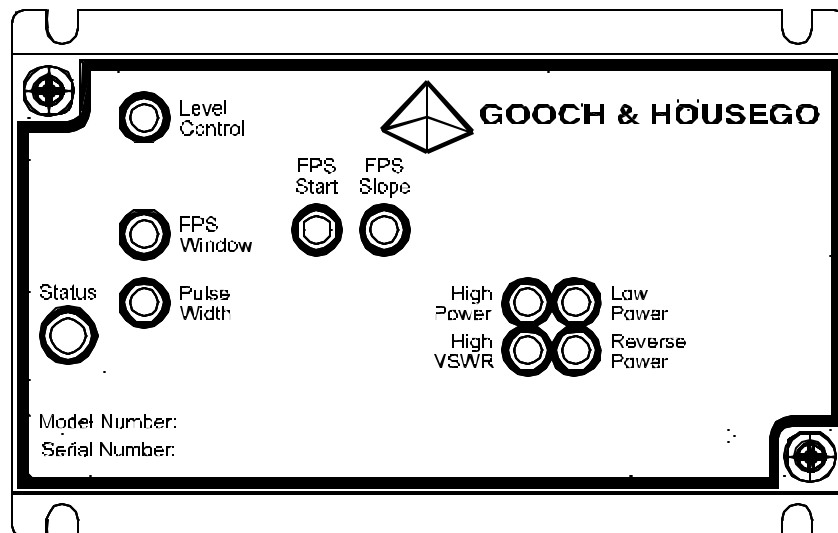

FPS ADJUSTMENTS FIGURE 1

Driver Adjustments

Change in RF Output made by the
FPS Slope control

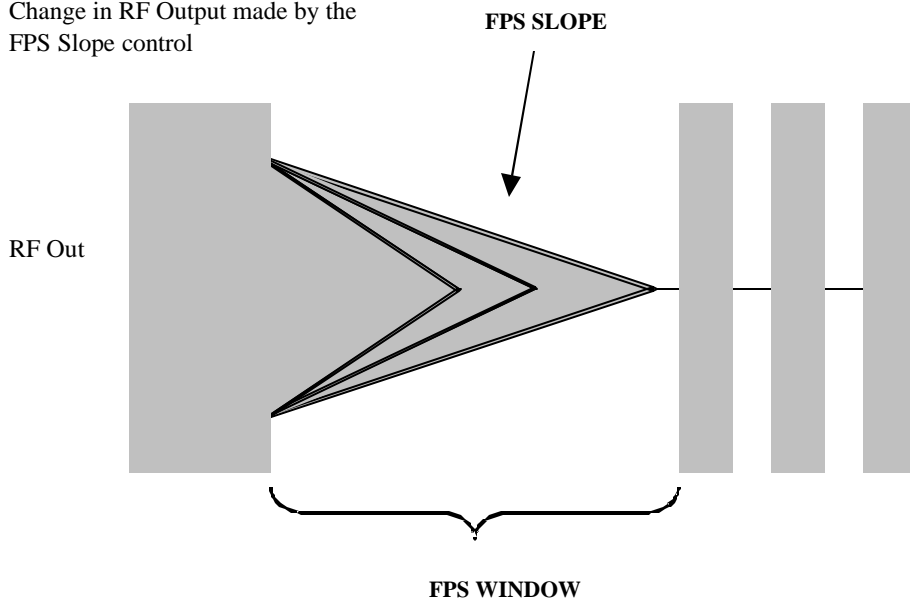

Change in RF Output made by the
FPS Start control

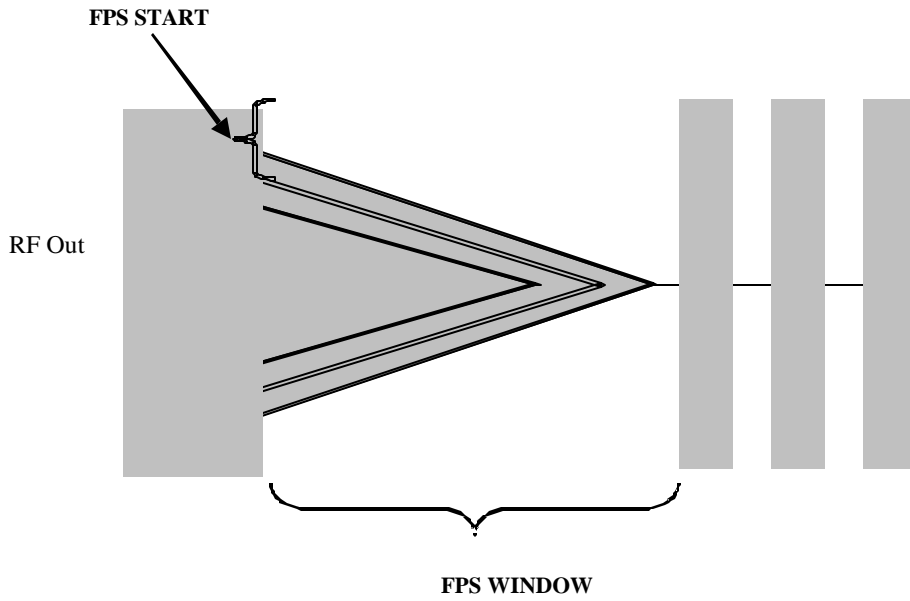

FAULTS

- HP – High Power Fault – The module attempted to output more power than the maximum set allowable level, as set by the High Power Fault control. This will output a TTL low on fault on pin 9. Adjust the **RF Level** control down.
- LP - Low Power Fault – The module is outputting less power than the Low Power has been set for. This will output a TTL low on fault on pin 8.
- High VSWR Fault (Voltage Standing Wave Ratio) – The module has been connected to a load that does not match 50 Ω , or the load has become damaged, or the load has been disconnected. This will output a TTL low on fault on pin 10.
If a mismatch is detected, turn the DC power off. Replace the load or Q-switch with a good 50 Ω load or good Q-switch.

ZERO CROSS, SYNC OUTPUT, AND ENABLE

- Zero Crossing Enable (pin 7) normally: TTL high or no connection- disabled, TTL low- enabled
If model # is (-ZC): TTL high or no connection- enabled, TTL low- disabled
- Zero Crossing Function: Normally, the Zero Crossing is disabled. Under this control condition the Digital modulation, both fixed and variable and the FPS input immediately controls the RF power with out regard to the phase of the RF energy being produced. If the Zero Crossing is enabled, then the Digital modulation is held off until the next zero crossing of the RF energy, therefore producing a RF output, which is consistent from one pulse to the next. There may appear to be jitter on the output compared to the input modulation signal. Use the sync output pin 1 to sync to the output pulse.
- Sync Output (pin 1) The Sync is normally set to output a 3.3 V inverted signal, which is synchronized to the input signal on the fixed, variable, or FPS inputs transitions. Enabling the Zero Crossing function causes the Sync to also be synced to the zero crossing of the RF energy.
- Enable (pin 11) For normal operation a TTL High or no connection on pin 11 enables the Driver.
- Stand By A TTL Low on pin 11 causes the Driver to be placed in Stand By Mode and limits the power dissipation to 3 watts.
- Reset A momentary TTL Low on pin 11 resets the Driver - after the cause of the fault is removed.

OPERATING PROCEDURE

TURN ON AND TESTING:

1. Unpack the module and check for obvious shipping damage. If the unit is not damaged, continue with the testing steps. If the unit is damaged, notify the carrier and your supplier.
2. Ensure proper heatsinking for the unit. See page 4 for requirements
3. Attach a 50Ω load capable of dissipating 2 to 24 watts* to the RF output of the unit. It is recommended to use RG-58 coaxial cable. *See the Acceptance Test Report for output power setting for this unit.
4. Apply the proper voltage to the 15V connector and the return.
5. Set up the external indicators if needed. Use +3.3 volt to the indicators.
6. Modulation control:
 - A. Fixed Mod in
Apply a TTL level modulation signal to pin 3 on the CONTROL connector. On the rising edge of a TTL signal, the driver's RF output will be off for a time duration set by the PULSE WIDTH control (1μs to 20μs). At the end of the pulse time, the driver RF output is returned to the normal output level, as set by the RF LEVEL ADJUST. The width of the pulse applied must be greater than 50 nanoseconds. Fixed modulation will operate to a maximum rate of 500kHz.
 - B. Variable Mod in
Apply a TTL level modulation signal to pin 5 on the CONTROL connector. When the signal is a TTL HIGH, the driver's RF output is off. When the signal is a TTL LOW, the driver RF output is at the normal output level, as set by the RF LEVEL ADJUST.
 - C. Analog in pin 6 or FPS in pin 2. See control diagrams for the signals needed for these control options. **Only the one option, which was specified when the unit is ordered, is available.**
 - **For FPS Control Option: See Figure 2**
Apply a TTL signal to pin 2. On a TTL Rising Edge, The circuit will begin the reduction of the RF power decreasing as set by the FPS window - 20 to 300 μs. The "Mod in fixed" or "Mod in variable" will pulse the RF to the level set by the ramp **during** this FPS period.
 - **For PPK Control Option: See Figure 3**
Apply a TTL signal to pin 2. On a TTL Rising Edge, The circuit will begin the reduction of the RF power, decreasing as set by the FPS window -20 to 300 μs. The "Mod in fixed" or "Mod in variable" will pulse the RF off **after** this period.
 - **For R05 Control Option: See Figure 4.**
The output RF power is roughly proportional to the voltage on pin 6 **during** the time the "Mod in fixed" or "Mod in variable" pulse is applied. No signal is necessary to output RF.
 - **For A05 Control Option: See Figure 5**
The output RF power is roughly proportional to the voltage on pin 6. The maximum RF output is achieved with 5 volts input. **5 Volts applied to this port is necessary for full RF output.** Apply an analog signal to pin 6 to control RF output level to control the laser's output energy in CW or pulsed mode.
7. Setting Controls:

Refer to 'Controls' for descriptions of the variable potentiometers that may be adjusted using a screwdriver, through the openings in the driver casing.
8. Test the various parameters as listed in the specifications listed on page 4.

OPERATING PROCEDURES:

1. Attach a Q-Switch capable of dissipating the power specified for the driver (2 to 24W*), to the RF output of the unit. It is recommended to use RG-58 coaxial cable. * See the acceptance test report for value.
2. **Follow the procedures listed in the Q-Switch Device manual for mounting the Q-Switch in the laser and for adjusting it for minimum insertion loss and maximum output power.**
3. Ensure proper heatsinking of the Driver module.
4. Apply the proper voltage to the 15V connector and the return.
5. Apply the appropriate modulation signals to the "Mod in Fixed" pin 3 or the "Mod in Variable" pin 5 to set the modulation rate of the driver to modulate the output of the laser.
6. Apply the appropriate modulation signals to the "Mod in Analog" pin 6 **or** to the "FPS in" pin 2 as required for the control option for this module.
7. Monitor the external fault LEDs if set up.
8. Use the enable to reset any faults after removing the cause of the fault.
Momentary TTL Low on pin 11.
9. The Driver module may be placed in stand by mode by a TTL Low on pin 11.

See the signal control diagram, Figures 2, 3, 4, 5, on the following pages.

FIGURE 2

FIRST PULSE SUPPRESSION OPERATING MODE CONTROL DIAGRAM

390XX-YYDMFPS-SC Control Diagram

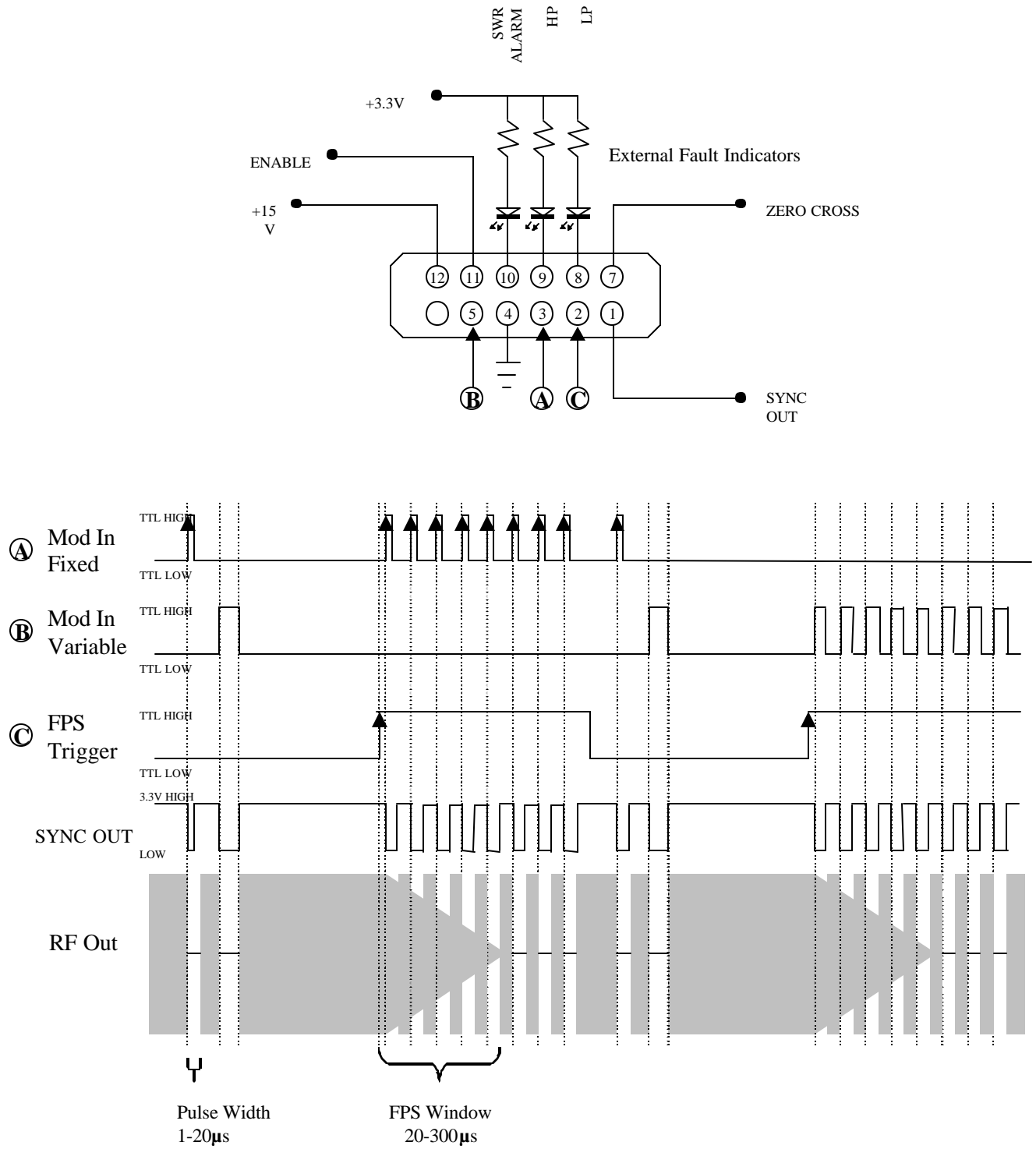

FIGURE 3

PRE PULSE KILL OPERATING MODE CONTROL DIAGRAM

390XX-YYDMPPK-SC Driver Control

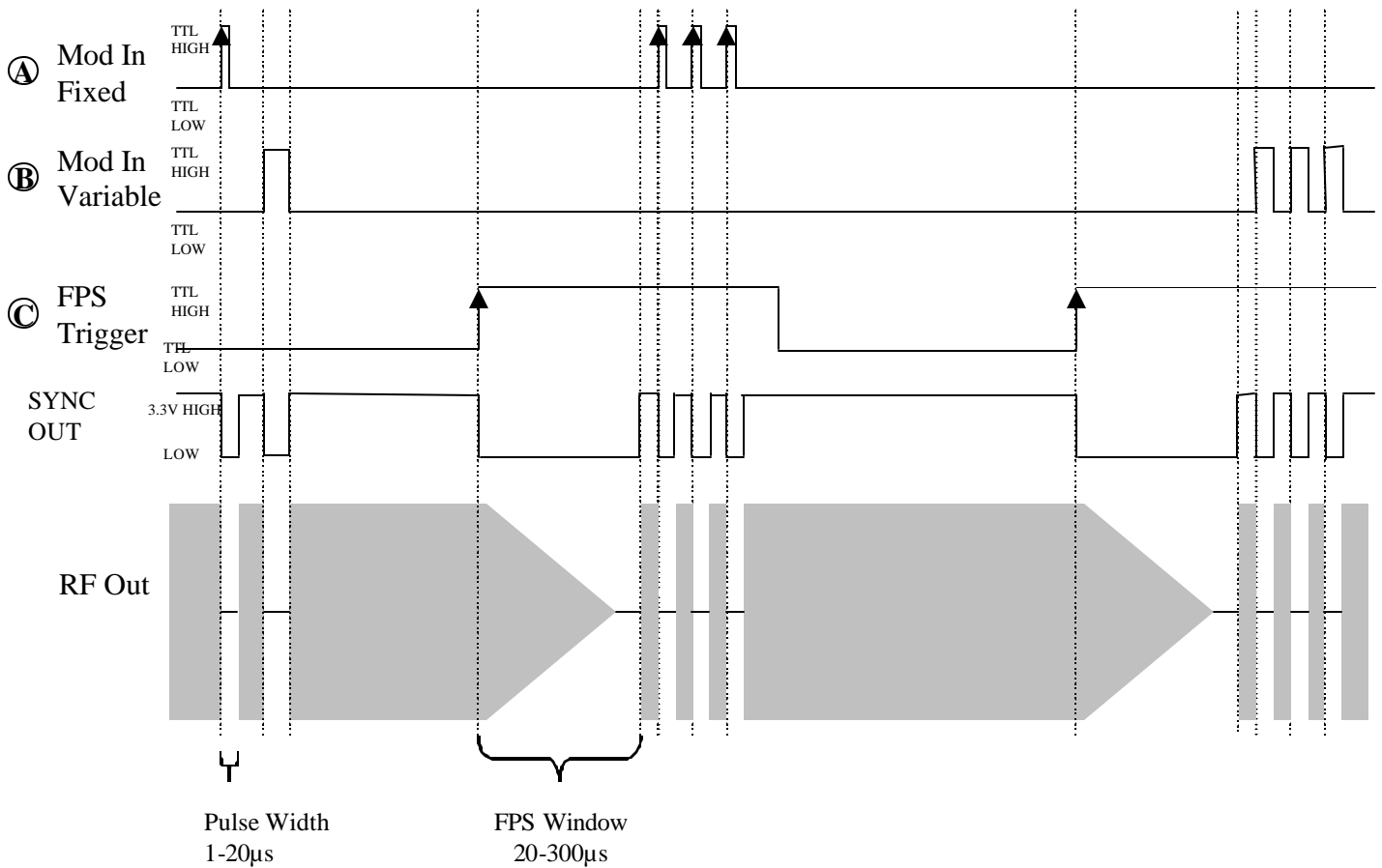
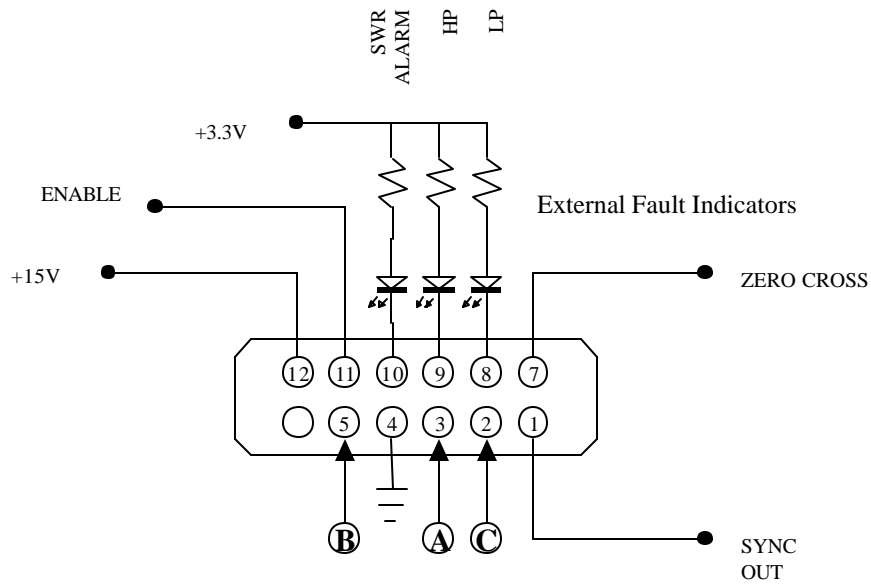

FIGURE 4

RF SWITCHED TO ANALOG CONTROL OPERATING MODE CONTROL DIAGRAM

390XX-YYDMR05-SC Control Diagram

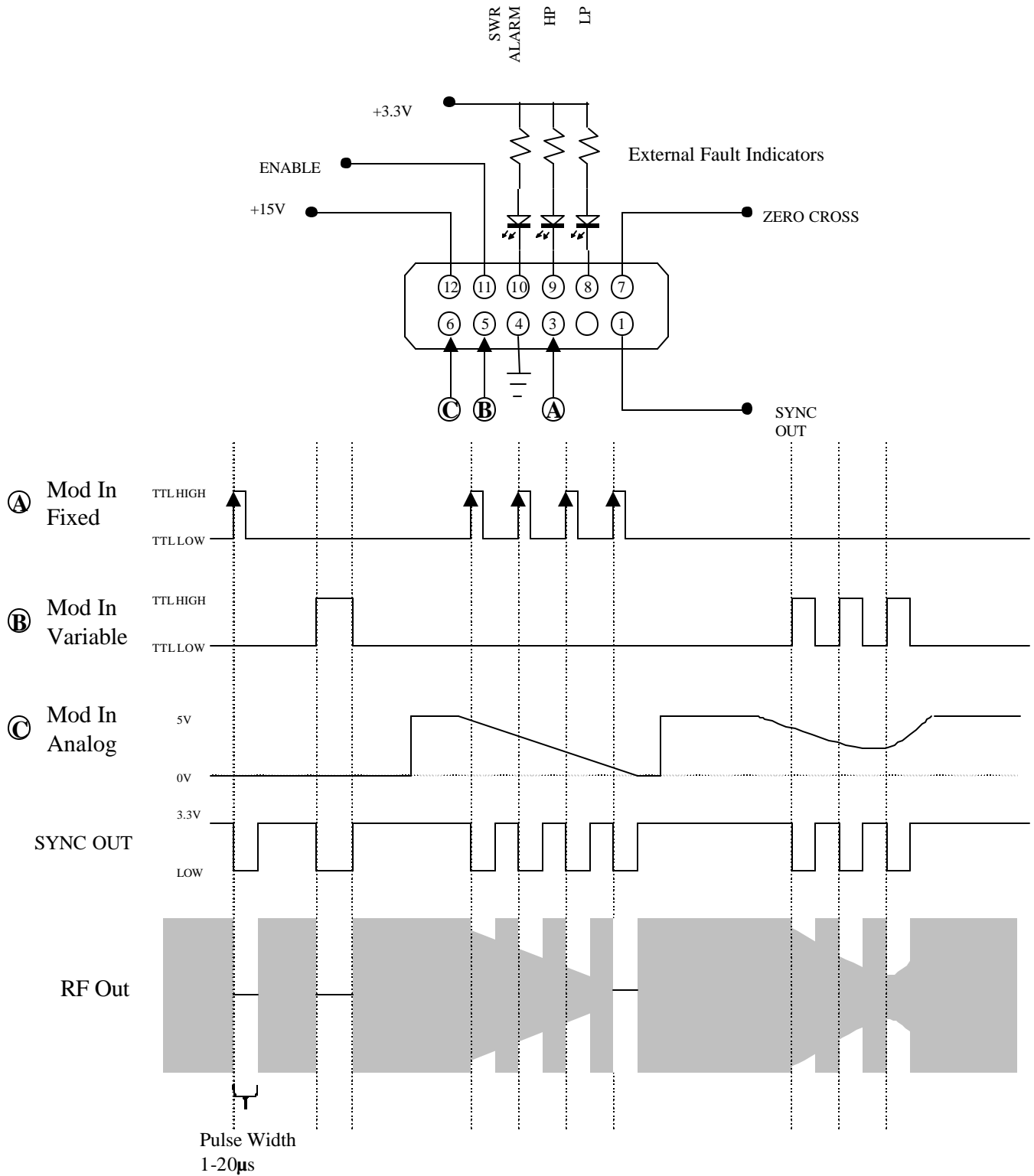

FIGURE 5

ANALOG CONTROL OPERATING MODE CONTROL DIAGRAM

390XX-YYDMA05-SC Control Diagram

